

VTV VALVE FABRICATED BASKET STRAINERS

Fig : STV-204B

FEATURES

SCREENS: 1/8" perforated type 304 stainless steel on sizes 2" to 24". Other perforations, meshes and materials are available upon request

CONSTRUCTION: Standard units are fabricated with slip-on flanges in standard pressure classes up to 2500 lb. Other flange styles and welded connections are available per your specifications

CODES: Fabricated to ASME B31.1, ASME B31.3 and/or ASME Section VIII , Div. 1. Latest Revision

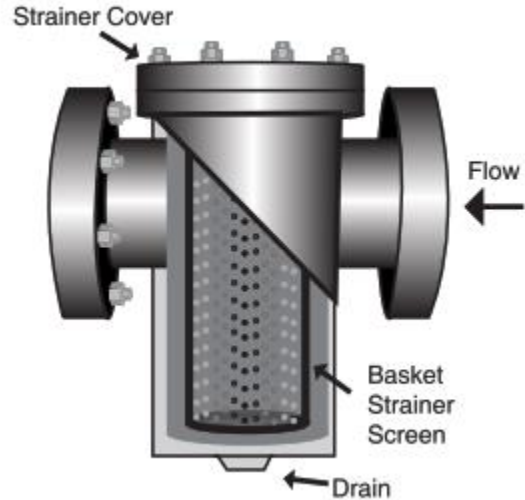

OPTIONS

- Available in sizes 1/2" through 48". Larger sizes available. Consult factory
- Dimensions can be modified to suit customer requirements
- End connections available in RF flanges, RTJ flanges or butt weld.
- Various body and screen materials and coatings are available.
- Special screen open area ratios
- Quick-opening cover
- Cover lifting davits
- Special nozzle positions
- Reduced inlets and outlets
- Self-Flushing assembly
- Vent and pressure differential connections
- Special floor stands and mounting hardware

PRESSURE AND TEMPERATURE RATINGS

Model	Body Material	Maximum Design Pressure M.A.W.P. at 100°F	Low Temperature Limit – M.D.M.T
150BFSBW	Carbon Steel	285 psig	-20 °F
150BFSSBW	304/316 Stainless Steel	275 psig	-20 °F
150BFSSLBW	304L/316L Stainless Steel	230 psig	-20 °F
300BFSBW	Carbon Steel	740 psig	-20 °F
300BFSSBW	304/316 Stainless Steel	720 psig	-20 °F
300BFSSLBW	304L/316L Stainless Steel	600 psig	-20 °F
600BFSBW	Carbon Steel	1480 psig	-20 °F
600BFSSBW	304/316 Stainless Steel	1440 psig	-20 °F
600BFSSLBW	304L/316L Stainless Steel	1200 psig	-20 °F

All models will be designed to the maximum design pressure unless alternative design conditions are specified. In some cases a cost savings may result if lower design conditions are acceptable.

DIMENSIONS AND WEIGHTS FOR SERIES 150B

		DIMENSIONS											
Size		A		B		C		D		E		Weight	
mm	in	mm	in	mm	in	mm	in	mm	in	mm	in	kg	lbs
50	2	324	12-3/4	283	11-1/8	190	7-1/2	15	1/2	635	25	39	85
80	3	356	14	318	12-1/2	200	8	20	3/4	724	28-1/2	63	140
100	4	406	16	356	14	210	8-1/4	25	1	775	30-1/2	66	145
125	5	457	18	432	17	184	7-1/4	25	1	775	30-1/2	72	160
150	6	508	20	432	17	241	9-1/2	25	1	914	36	93	205
200	8	559	22	533	21	279	11	40	1-1/2	1092	43	190	420
250	10	813	32	635	25	419	16-1/2	40	1-1/2	1473	58	294	650
300	12	889	35	711	28	425	16-3/4	40	1-1/2	1562	61-1/2	546	1205
350	14	940	37	838	33	400	15-3/4	50	2	1638	64-1/2	725	1600
400	16	1067	42	914	36	464	18-1/4	50	2	1842	72-1/2	890	1965
450	18	1181	46-1/2	1016	40	508	20	50	2	2032	80	997	2200
500	20	1321	52	1168	46	559	22	50	2	2286	90	1450	3200
600	24	1626	64	1397	55	705	27-3/4	50	2	2807	110-1/2	2039	4500

DIMENSIONS AND WEIGHTS FOR SERIES 300B

		DIMENSIONS											
Size		A		B		C		D		E		Weight	
mm	in	mm	in	mm	in	mm	in	mm	in	mm	in	kg	lbs
50	2	378	14-7/8	305	12	200	8	15	1/2	711	28	89	196
80	3	419	16-1/2	400	15-3/4	235	9-1/4	20	3/4	870	34-3/4	114	250
100	4	473	18-5/8	403	15-7/8	257	10-1/8	25	1	918	36-1/8	136	300
125	5	514	20-1/4	435	17-1/8	276	10-7/8	25	1	987	38-7/8	182	400
150	6	622	24-1/2	486	19-1/8	295	11-5/8	25	1	1076	42-3/8	218	480
200	8	632	24-7/8	559	22	343	13-1/2	40	1-1/2	1416	55-3/4	310	680
250	10	899	35-3/8	692	27-1/4	388	15-1/4	40	1-1/2	1454	57-1/4	500	1100
300	12	1000	39-3/8	772	30-3/8	442	17-3/8	40	1-1/2	1654	65-1/8	750	1650
350	14	1054	41-1/2	838	33	495	19-1/2	50	2	1829	72	1182	2600
400	16	1207	47-1/2	988	38-7/8	536	21-1/8	50	2	2061	81-1/8	1250	2750

Dimensions shown are for flanged and buttweld strainers. Dimensions can be modified to suit customer requirements

Colton has a policy of continuous product research and improvement and reserves the right to change design and specifications without notice